



Download Brochures



iqubx 
www.iqubx.com

MODULAR INTERIOR SYSTEMS
CUSTOMIZABLE | INNOVATIVE | SUSTAINABLE



FEATURES



Innovative, Unique patented designs



Greenpro certified, recycled aluminum 6063 alloy T6 tempered



Sophisticated engineering



Very High performance



Made completely in India



Offices | Residences
Hospitals | Institutes |
Universities
Smart Cities | Airports
Retail | Hotels
Railway & Metro Stations

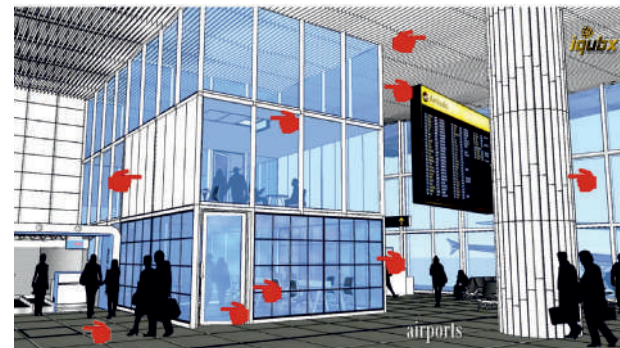
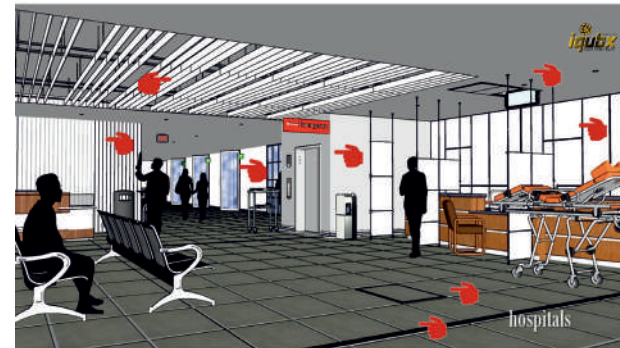
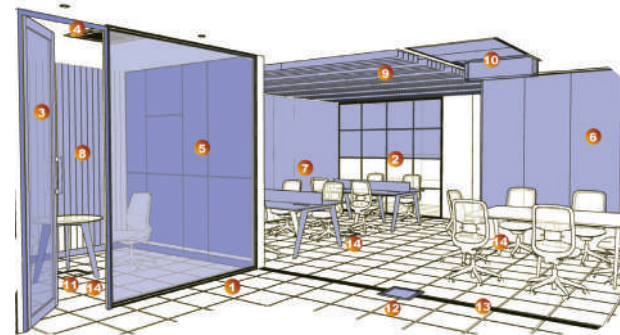

BENEFITS



Ultra Fast installation on site



Minimum manpower on site



Very Economic pricing



Highly Customizable as per requirements



Modularity - Modifiable even post-installation



Relocatable



Minimum Turn-around-time



Minimum components- better logistics & maintenance



Made in India, future availability of components



Caters to Sustainable project requirements



New Custom MODULAR solutions designed as per your requirements



3 Patents



Awards & Recognitions



100+ Design Registrations



80+ Greenpro Registrations



We help

architects, designers, contractors
& end-users to create dream
interiors through our innovative,
sustainable & highly
customizable modular solutions.

We can provide
custom modular solutions as
well

- 04 Modular baffle ceilings
- 06 Ceiling trap doors
- 08 Glass partition systems
- 11 Office & Meeting pods
- 12 Doors
- 13 Door frames
- 14 Demountable partition systems
- 15 Dry wall cladding partitions
- 16 Open modular frame structure system
- 17 Work stations leg systems
- 18 Floor Trunking System
Floor Junction Box, Floor box, Floor Raceways
- 19 Miscellaneous
Panelings, Skirting Boards, Corner Guard,
Transition Profile, Modular Partitions

WHAT do people SAY?



All copyrights, trademarks, Intellectual property rights, patents reserved in name of IQUBX pvt ltd and its directors. Any copying of logo, images, designs, product designs without explicit written permission of the directors of IQURX pvt ltd shall be a punishable offense. All the product designs are IPR protected.

BFC2 with laminated MDF, lacquered glass and cork used to create edge lit portal



BFC2 surfaces can be hand-painted or pasted with mosaic tiles etc

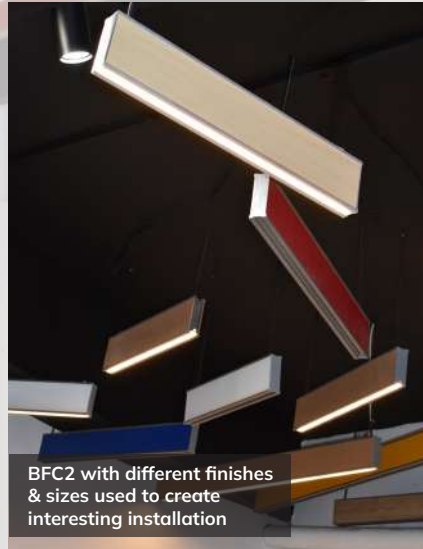

BFC2 with different finishes & sizes used to create interesting installation

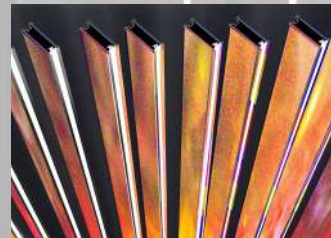
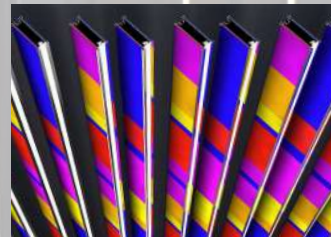

BFC2 is patented system with changeable 4mm finishes to create unique dynamic ceilings

BFC2 120 x 41.5 mm

Patented baffle
Changeable 4mm material finish on 3 surfaces

Flexibility of changing finishes later

- Lacquered glass
- Cork
- ACP sheet
- Laminated MDF
- Veneer
- Printed vinyl
- Edge lit acrylic
- Greenpro certified
- 6063T6 Aluminium alloy (Recycled)

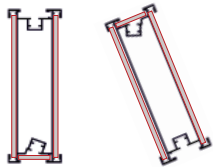

BFC12

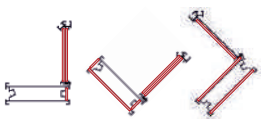

MODULAR BAFFLE CEILINGS



BFC3 with different finishes and creative curvilinear or angular shapes can be used for automobile display, conference rooms or any bold interiors

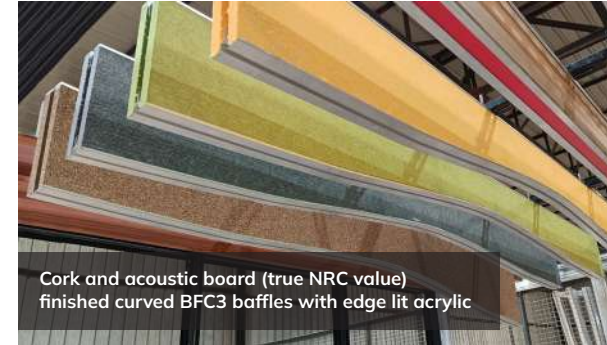

Cork and acoustic board (true NRC value) finished curved BFC3 baffles with edge lit acrylic

BFC3 Any height x 39mm

- Baffle of any height possible
- Creative shaping
- Acoustic NRC as per infill material
- 12mm material finish
- ACP sheet
- Mineral tiles
- Acoustic board
- Pre Laminated particle board
- Veneer / laminate / cork on WPC
- Gypsum board with wall paper
- Printed vinyl



Truss construction of BFC3



Mineral tiles in BFC3 to give true NRC value



Interesting use of multiple colours in diagonal layout in a mall



Conversion of standard extrusion tubes into a baffle with proprietary clips is possible

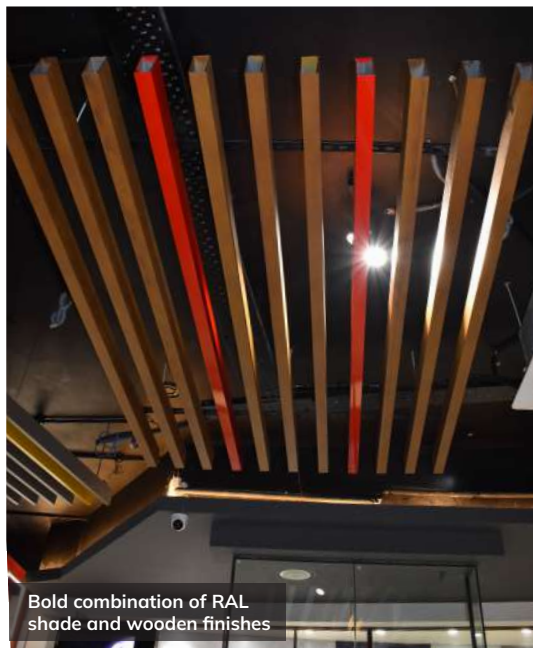

Bold combination of RAL shade and wooden finishes



BFC4 Vertical Baffles



BFC4 100 x 25

Any RAL shade, wooden powder coat anodized finishes

Conversion of standard extrusion tubes into a baffle with proprietary clips is possible

- 100 x 50
- 150 x 75
- 200 x 50

size of any available generic section in market

Patented

Innovative

Innumerable exotic finishes

Flexible & creative shapes / sizes

Greenpro certified by IGBC

iqubx

CEILING TRAP DOOR



Hanging plumbing and traps

Above ceiling smoke detectors

Electrical conduits & Geysers etc

SERVICES ABOVE FALSE CEILING

HVAC machines and ducts

Fire pipes & valves

Sprinklers & other fire suppression devices

In contemporary commercial and residential interiors, most of the services like fire pipes, air conditioning, fire detection and suppression systems, plumbing and more are installed at ceiling level. Maintenance and repair of these services require sturdy and easily operable access trap doors of appropriate size.

Since only fixed and small size modular aluminium trap doors have been available till now, interior designers and architects usually go in for wooden trap doors. Regardless of the brand, all these modular trapdoors have similar designs which if made in bigger sizes easily warp over time. And the wooden ones deteriorate even faster.

IQUBX cutting edge IPR protected and Greenpro certified modular ceiling trap doors can be easily made in any big or small customized size, without the shutters getting bent or warping over time. The largest delivered till date is 18 x 8 feet (5500 x 2400 mm).

These big size trap doors allow complete unobstructed opening as all the shutters can be slid to one or both sides. Each shutter is secured with steel wires, and has Allen key mechanism.

These trap doors blend seamlessly in any interior with just 2 to 3mm groove around the shutters and can accommodate various 12mm material and finishes like gypsum / MR board, POP ceilings, / ACP / Laminate / Veneer on WPC / WPC / wooden / louvered. IQUBX trap doors can even be retrofitted in place of old wooden trapdoor opening.

These are being widely used in interior projects like residential towers, apartments & villas, Universities Malls, Hospitals, Hotels, Airports & offices, across the country and being exported as well



FIXING A CEILING TRAP DOOR



There is minimum groove of just 2mm to 3mm between inner and outer frames due to Innovative sliding hinge



Multiple shutter configurations as per size requirements

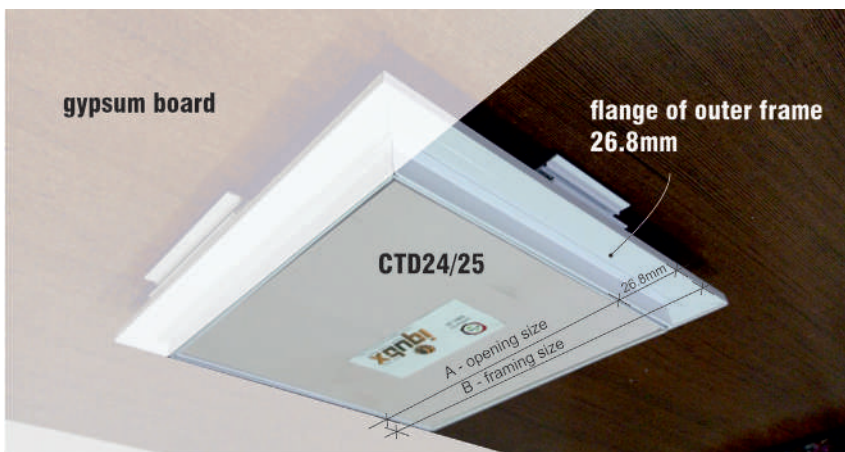

GUIDELINE FOR GIVING DIMENSION OF TRAP DOOR WHILE ORDERING

- The order should be given for A, opening size of gypsum
- Care should be taken by ceiling contractor to do the framing support 26.8mm inside from all sides of gypsum opening, against which ceiling trap door outer frame may be fixed with screws etc
- Ideally, the ceiling trap door should be procured beforehand and fixed to the ceiling frame before fixing of gypsum board. The actual size of opening will be 26.8mm shorter on all four sides.

CTD25

Latest design with strong construction, modifiable on site, minimum groove of just 2mm to 3mm visible around shutters, ideal for super big size trap doors

Unique design worldwide

IPR protected - patented

Any Custom sizes

Big sizes (Largest made 18' x 8' till now)

Light weight

Strong shutters don't warp

Any material finish 12mm
(Gypsum / MR board / ACP / Laminate / Veneer on WPC / WPC / wooden / louvered)

6063T6 Aluminium alloy (Recycled)

Greenpro certified by IGBC



CTD23

Patented, with flange of approx 5mm and proprietary continuous aluminium hinge. Maintenance free

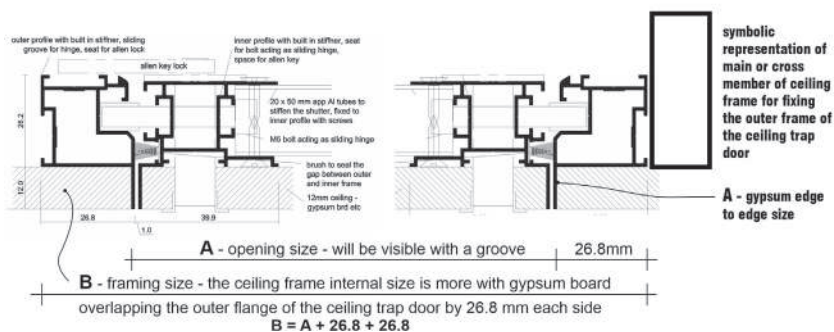
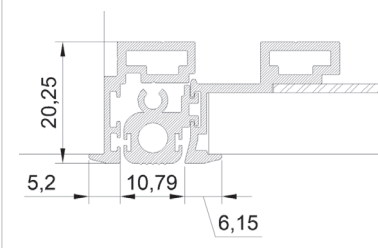



iqubx

MODULAR GLASS PARTITIONS

GP18100
22 x 100 mm

GP2160
22 x 60 mm

GP2175
22 x 75 mm
(currently for single glass only)



GP1800D
Double Glass 12mm



STC54
Highest Acoustic Insulation reported Worldwide



High performance - high certified acoustic insulation, + STC 45db

Flexible glass configuration - can accommodate single, double and DGU Glass configurations just by shifting or using different mouldings
8, 10, 12 mm toughened glass - single, double
11.5 to 21.5 mm laminated glass and more
VIG (DGU) glass from 18mm - 60mm

Upgradable from single glass to double or VIG glass easily at any time,
if evolving requirements of user require higher sound insulation, without changing the system

Simpler logistics by using the same system throughout a project

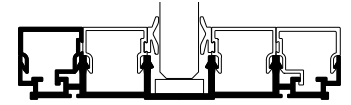
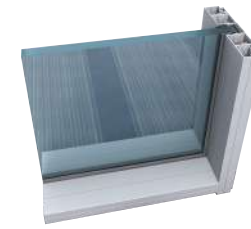

GP18100S Single Glass

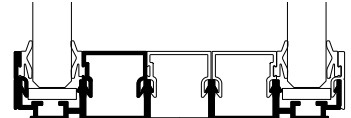
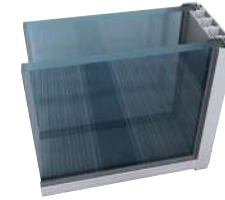

GP18100D Double Glass

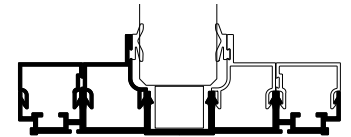

GP18100V VIG/DGU Glass



GP2160 Series

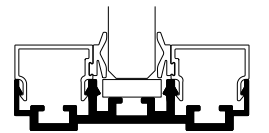

GP2160S
Single Glass

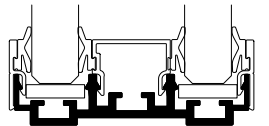

GP2160D
Double Glass

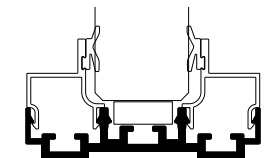

GP2160V
VIG/DGU Glass

GP1750 / GPC1750

17 x 50 mm

Slim section

Double colour design with half base & half moulding visible

Can have large plain glazed surfaces or grid / crittall design in any shape and size option

True mechanical grid joinery

For 8 - 12 mm toughened float glass - single



GPC1415

14 x 15 mm

Faux grid section for use from both sides of glass

True mechanical joinery

Can be used to create screens, planters, table base

Greenpro certified

6063T6 Aluminium alloy (Recycled)



GPC2060

20 x 60 mm

Very strong

Can be opened from one side - usable for exterior fixed windows and facade

Flexible grid shape and size grid/crittall design in any shape & size option

True mechanical grid joinery

For 4 - 8 mm toughened float glass - single



GP1436

14 x 36 mm

Ultra Slim section

Side mouldings allow chamfered joinery of frame

Can have large plain glazed surfaces

True mechanical joinery

For 10 - 12 mm toughened float glass - single

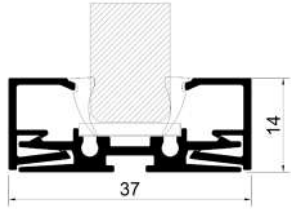

Slim footprint

GP4028

40 x 28 mm

Can be opened from one side - usable for exterior fixed windows & facade

Double lock in moulding

High sound insulation

For 10-12 mm toughened float glass - single

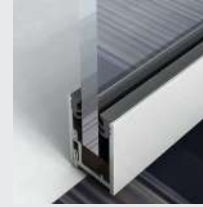
**GPSL Series
Sliding Partitions****GPSL01**

14 x 45 mm

GPSL-GD03

26 x 40 mm/60 x 40 mm

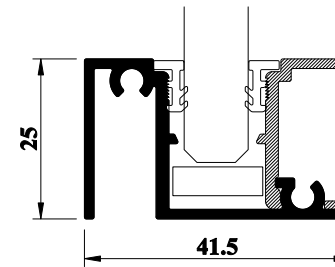
**GP2510**

25 x 41 mm

GP2512

25 x 50 mm

High sound insulation

10-12 mm glass - single

Greenpro certified

6063T6 Aluminium alloy (Recycled)





SINGLE SEATER



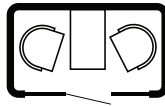

DOUBLE SEATER

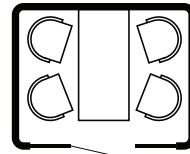

FOUR SEATER





Any size upto 12' x 12'
(or even more)

 
Ventilated Air Conditioning
Option

High Acoustic Insulation
(average 30dB - 40dB)



Flat Pack -
Knockdown Delivery

Flexible configuration of
glass/solid walls, finishes, sizes
(FINISHES - Acoustic, Laminate,
Veneer, Writable Lacquered Glass,
Fabric, Soft board, Cork)

Easy to fabricate & assemble
in any workshop
(Modular construction in
6063T6 Aluminium alloy
proprietary sections)

Multilayered high sound
insulation walls/glass

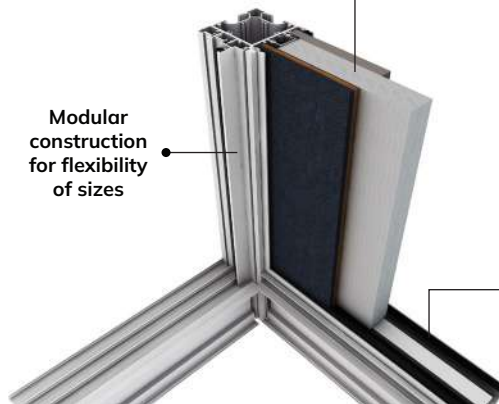
Modular
construction
for flexibility
of sizes



Can accomodate
glass/solid panels
on any side
due to unique
modular design



Time, temerature,
humidity display

Switch & socket
board

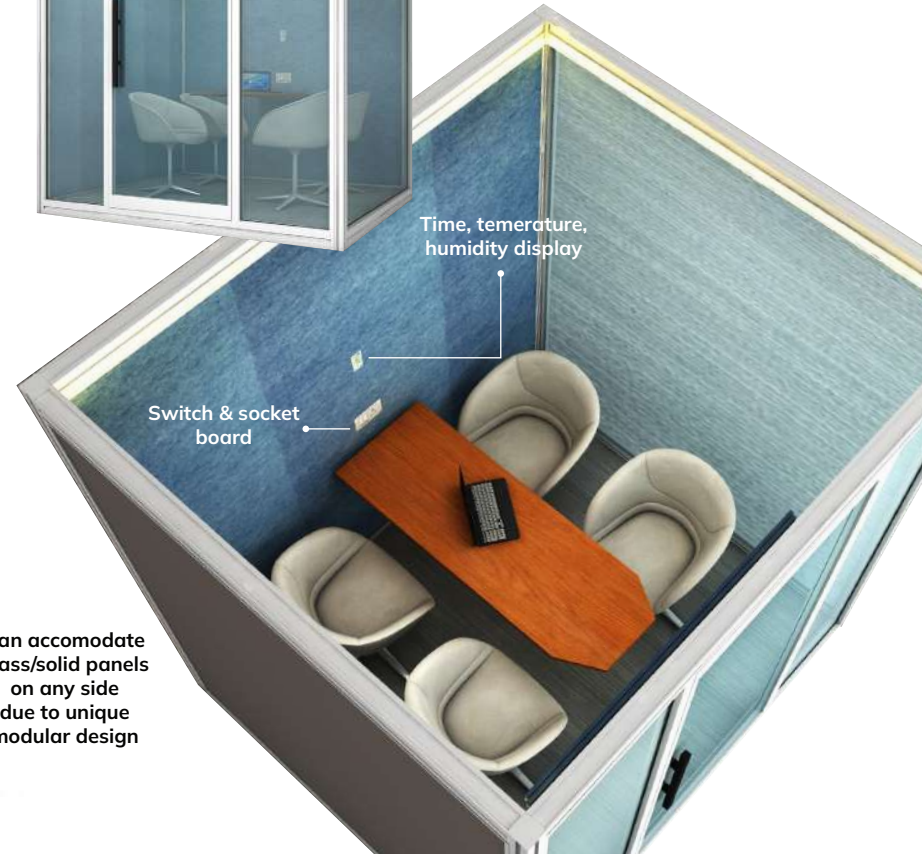

MODULAR PHONE BOOTHS OFFICE WORK PODS MEETING PODS WORK-FROM-HOME PODS

For Calls, confidential meetings, focussed
productivity, wellness breaks

- Open offices
- Co-working spaces
- Hotel lobbies
- Airports, metro stations
- Exhibitions & conferences
- Work-from-home

iqubx

MODULAR GLASS STILE DOORS

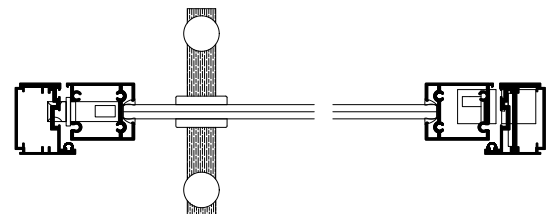
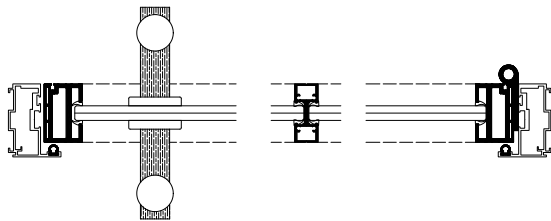
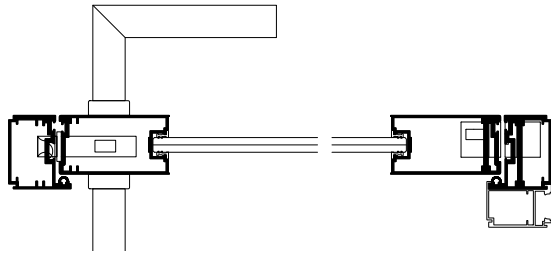
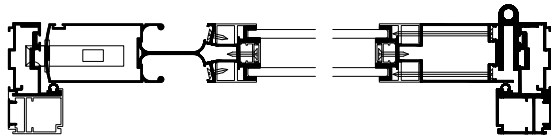

GD01 lock stile 145 x 40 mm
hinge stile 85 x 40 mm
rail 80 x 40 mm
With DF02-75, double 6mm glass, built in handle, butterfly hinge, dead lock
Integrated handle
Single glass 8-10 mm/double glass 6 mm
Can accommodate DGU (lock stile without integrated handle)

GD02 lock & hinge stile 75 x 40 mm
rail 90 x 40 mm
DF03-50, single 10mm glass, concealed hinge, mortise lock with lever handle
Single glass 8-10 mm
Can be made into a sliding door
Hardware options - concealed door closer, drop-seal, concealed / butterfly hinge, electronic access lock
Versatile & creative grid design options with true mechanical joinery

GD03 lock & hinge stile 26 x 40 mm
rail 60 x 40 mm
DF02-50, single 10mm glass, butterfly hinge, H handle with built-in lock
Single glass 8-10 mm
Ultra slim design
Very strong construction & joinery
Can be made into a sliding door & partition
Drop-seal & multiple lock/handle options
Versatile & creative Grid design options with true mechanical joinery

GD04 lock & hinge stile 48/45 x 40 mm
Rail 60 x 40 (GD03 rail optional)
DF03-50, single 10mm glass, concealed hinge, H handle with dead lock
Stile can be curved for rounded openings
Single glass 8-10 mm
Slim design
Drop-seal & multiple lock/handle options
Hardware options-drop-seal, concealed/butterfly hinge



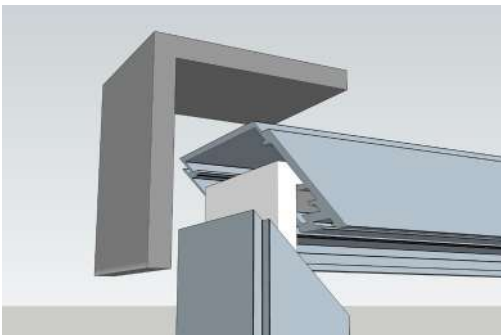

iqubx

MODULAR DOOR FRAMES



DF02

36 / 22 x 50
76, 102 ... (50+26xn) mm
14 mm rebate

Strong sturdy independent construction
Can be used for glass, solid partitions, as well as masonry
Modular extension in multiple of 26 mm can be used on 50 mm base section for different width of door frame
Accommodates any door upto 45 mm - aluminium or flush wooden doors
Double acoustic seal provision for high sound insulation

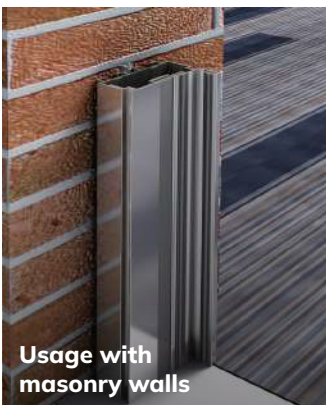
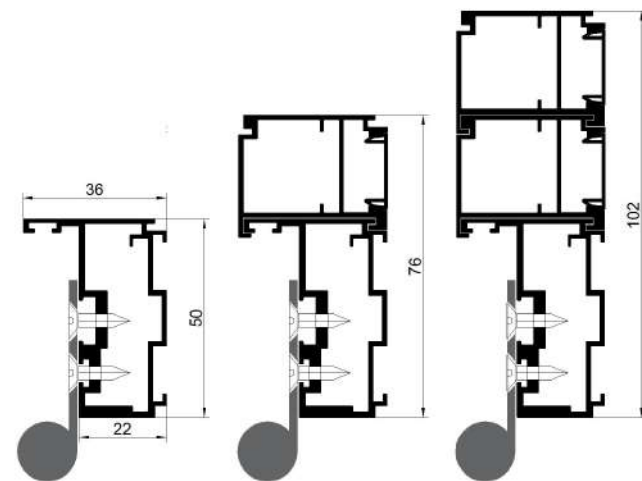

Usage with masonry walls

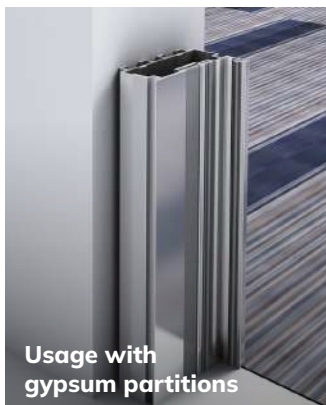

Usage with gypsum partitions



Usage with glass partitions



DF03

42.5 / 31.5 x 50
76, 102 ... (50+26xn) mm
11 mm rebate

Strong sturdy independent construction
Can be used for glass, solid partitions, as well as masonry
Modular extension in multiple of 26 mm can be used on 50 mm base section for different width of door frame
Accommodates any door upto 45 mm - aluminium or flush wooden doors
Can accommodate concealed hinge

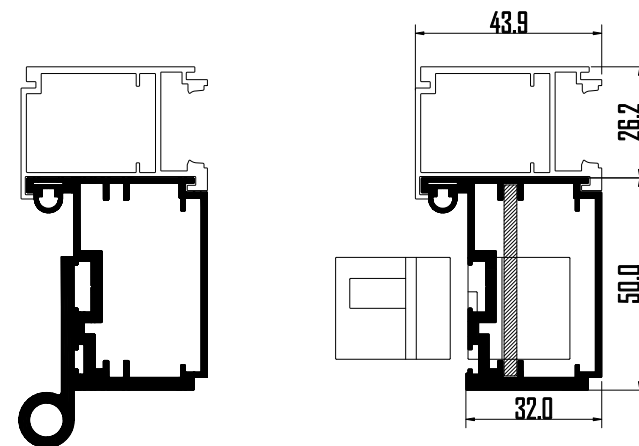



DEMOUNTABLE SOLID PARTITIONS

Post & rail with panels Modular construction

Very fast installation

Panels can be changed, removed & refixed to allow maintenance

Panels fixed with gaskets on frame for high acoustic insulation

Continuous cavity for conduits, other services & acoustic insulation

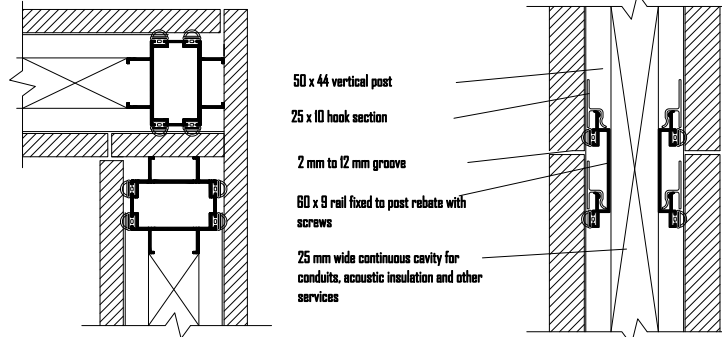

CORNER DETAIL
WPD3P PLAN

skin can be any 6-12 - 25 mm thk or other thickness material like prelaminated particle board, HPL, laminated ply or MDF, lacquered glass pasted on mdf, soft board etc

WPD3P SECTION

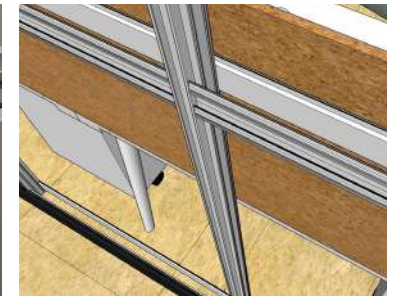
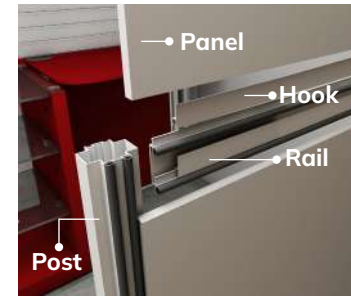
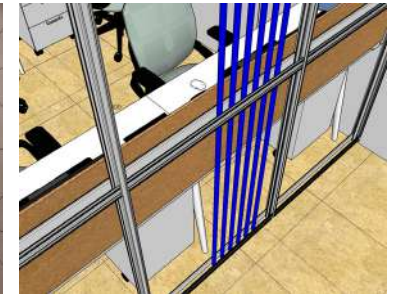
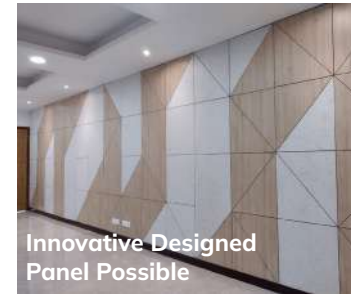

Panels of 6mm to 25mm of any finish can be installed - Prelaminated / Postlam board, Veneer/ lacquered glass, soft board, cork board, HPL etc

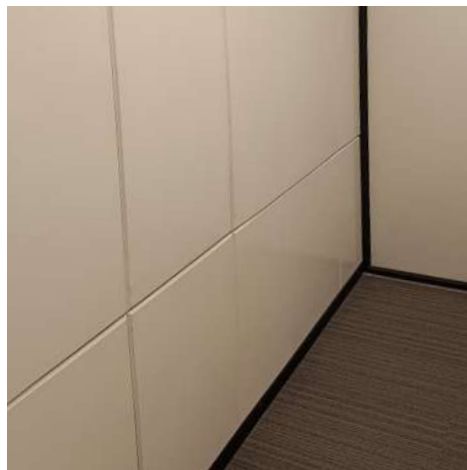

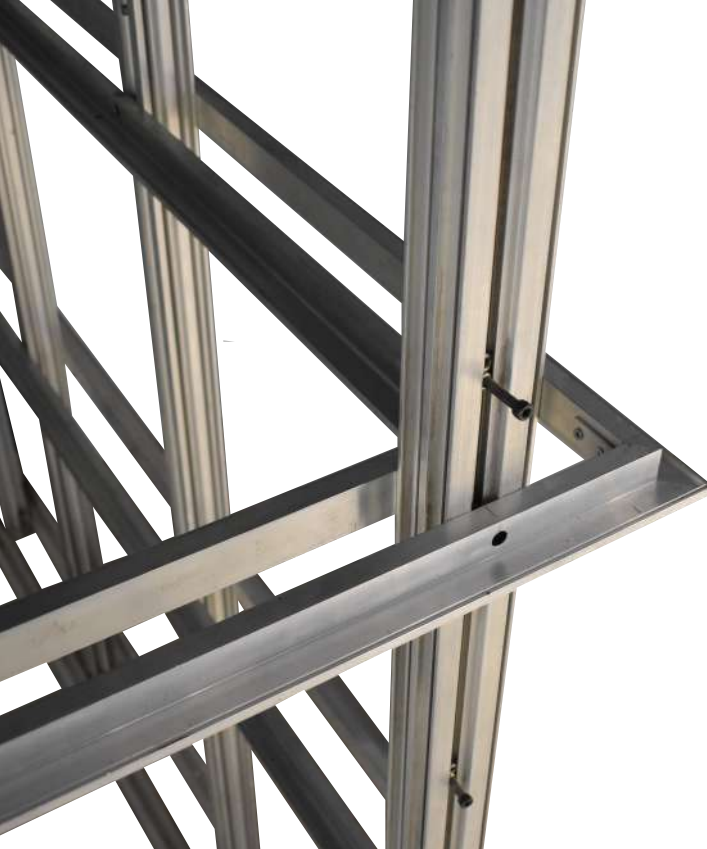

iqubx
**DRY WALL
CLADDING**

Dry wall cladding system can clad stone, tiles pasted on a board, cement board etc on existing surface

Dry wall cladding along with IQUBX open frame structure system can create partition walls for dry or wet areas

Easy to access services like plumbing etc by removing & refixing panels

Dry & modular construction makes it very fast to install, completely relocatable, modifiable

Can be used for creating dry partition walls in hotel / residential / Makeshift and permanent hospitals / offices

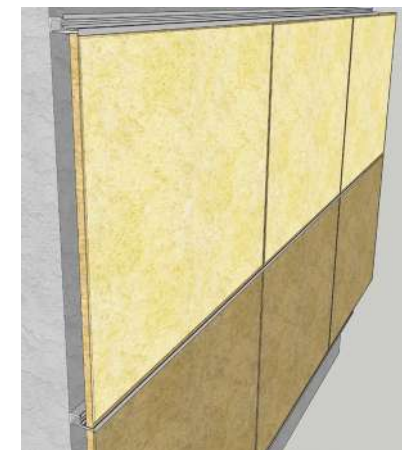
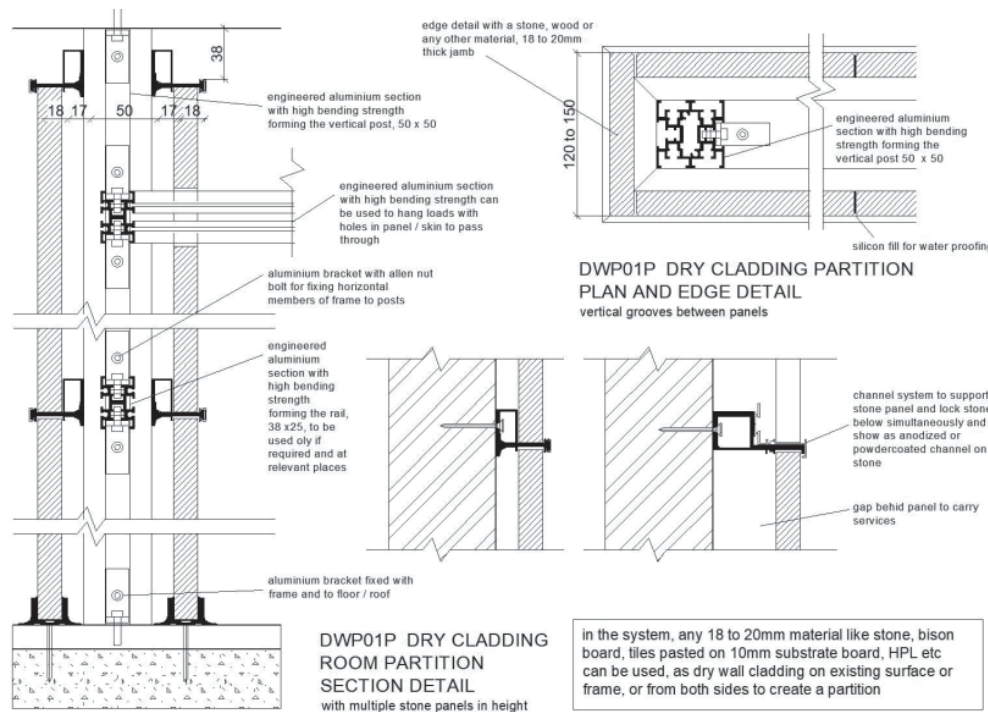

Dry wall cladding system used with onyx stone and backlit with LED is extensively being used in residential & hospitality sectors.



OPEN MODULAR FRAME STRUCTURE



OFRS

Highly modular construction

Quick install & uninstall

Strong sturdy Modular Joinery with minimum tools

Completely reusable, relocatable, modifiable

Good load bearing strength to mount accessories like fans, ACs, racks, partitions, doors etc

Greenpro certified

6063T6 Aluminium alloy (Recycled)

Use Cases

Industries & sheds (PEB) for office cabins, stores etc

Mall (for kiosks & Retail spaces)

Airports, Railway stations, Metro stations (for kiosks, Retail outlets)

Exhibitions (Stalls & Booths)

Offices (for office booths, floating conference rooms, even complete offices)



Main frame made of 50 x 50 IQUBX aluminium green certified proprietary section of Open Frame Rack Structure System. This is fixed to walls & floor with expansion bolts, creating strong Independent standing framing

Strong modular joinery doesn't require drilling holes etc for bracket fixing, making it feasible for repositioning brackets as per requirements. This allows easy modification and reuse/relocation



GMR Hyderabad Airport Partition
80' x 25'
Made in operational airport conditions

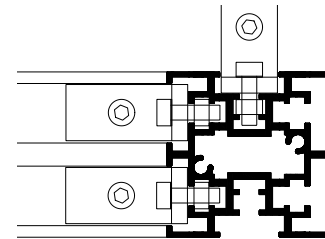
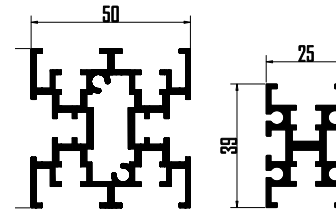

Freestanding Office Cabins
in Industrial Sheds

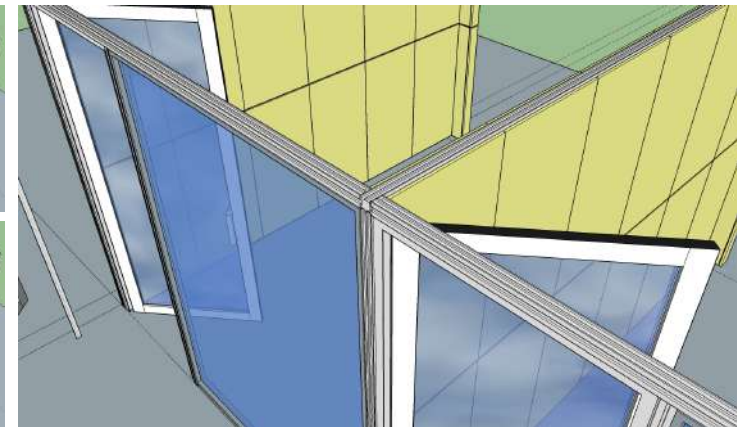
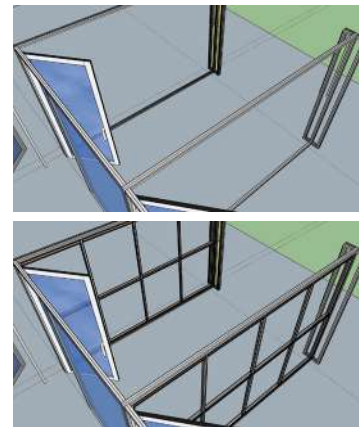



WORKSTATION UNDERSTRUCTURE

WSL01
WSLSQ55
WSLT60
WSGD03

Completely Aluminium

Versatile, Strong & sturdy

Modular knock-down

Modifiable on site

Beams act as raceways

Dual colour possible due to compound legs



WSLT60
Triangular Loop Leg
60 x 60 mm

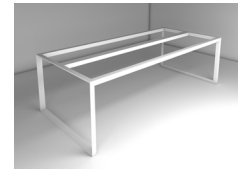
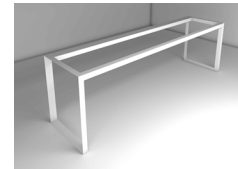

WSGD03

26 x 40, cover plate,
60x40 beams



Workstation understructure designed from GD03 sections

Flexible creative designs possible

Double colour options due to cover on main section

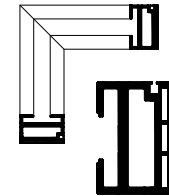

WSL01

Tapered Leg
75/45 x 40 mm

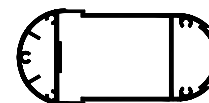

Workstation Raceways Beams

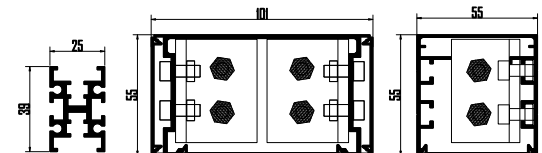



FLOOR TRUNKING SYSTEMS

Floor Junction Box

Can accommodate floor finishes like stone, tile, wood, carpet etc

Patented unique 3 component modular design

Any size, odd shapes

Assemblable and Modifiable on site

Good load bearing strength

Usable in Offices, Airports, Railway stations, Malls or even Residences

Greenpro certified

6063T6 Aluminium alloy (Recycled)

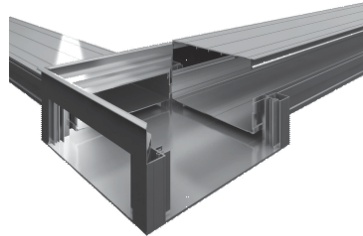

FB01 Electric Floor Box

Modular customized flexibility

55mm ht, length upto 2400 mm

Continuous failproof hinge

Width with any number of bays, first bay of 165 mm, additional bays of 93 mm each x n

Two bay 258 x 258 mm can be retrofitted in existing floor boxes

Greenpro certified

6063T6 Aluminium alloy (Recycled)

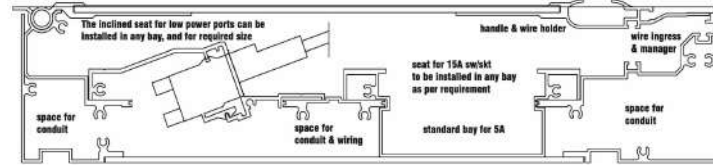
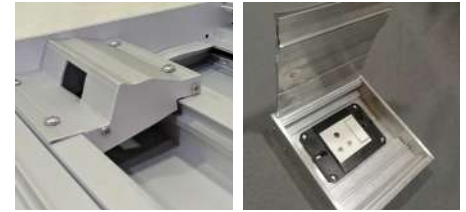

IQUBX FB01 electrical floor box outlet - 2 bay section

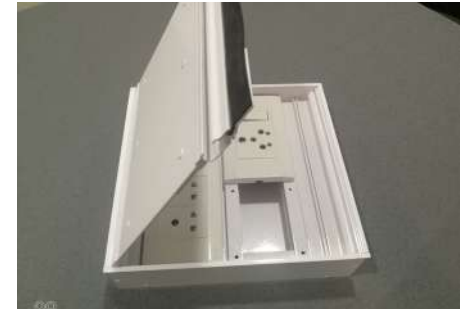

FB02 Electric Floor Box

Modular customized flexibility

95mm ht, length upto 2400 mm

Continuous failproof hinge

Width 1 bay 158, 2 bay 258 mm

Upto 10mm floor finish in lid

Greenpro certified

6063T6 Aluminium alloy (Recycled)



JB022 L/D/H (Lid / Double lid / Hinged)

for bigger sizes and floor finishes upto 19mm high load bearing 30 mm collar depth, ideally 60 mm ht onwards sizes of even 600 x 600 or more

JB023 L/D/H (Lid / Double lid / Hinged)

for medium sizes and floor finishes upto 10mm medium load bearing 20 mm collar depth, ideally 50 mm ht onwards sizes upto 450 x 450 recommended

JB22 & JB23 have similar construction, but different collar depth & load bearing capacity



Recyclable certified Green Building Material Ideal for LEED Projects



No loose covers means no accidents no tripping



Lid in cavity doesn't come loose, thus, no entry of dust, mites, bugs, rodents which may damage the wires and cause disease



Most economical solution as no wastage and can be self fabricated on site

Double lid or infact any design & shape possible as per requirement



RW011 Floor Cable Raceway 45 x 150

45 mm ht, 150 mm wide, stackable in width 150,300....

Can be laid exposed to floor finish, on walls, partitions

Snap-fit lid for easy access & maintenance of cabling

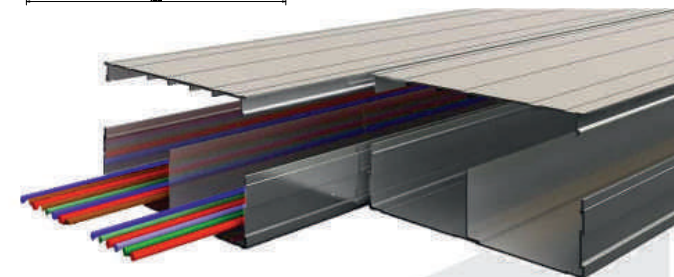
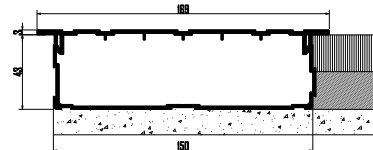



60 mm wide interlocking Aluminium panels
Can be used in smaller pieces with different finishes
Can be used for cladding straight or curved surface

Can be used from reverse side as well to accommodate different 4mm finishes:
Lacquered glass
Cork
ACP sheet
Laminated MDF
Veneer
Printed vinyl
Edge lit acrylic
Glass / ceramic mosaic tiles

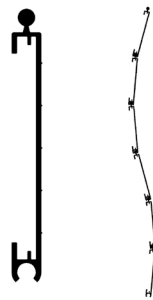

75 mm wide interlocking Aluminium panels
Can be used in smaller pieces with different finishes
Can be used for cladding straight or curved surface

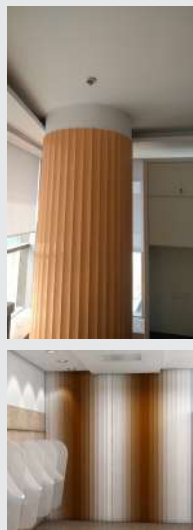

Modular Partitions



WS26 Airline 26 mm wide



WS54 Jetline 54 mm wide



Aluminium Skirting Boards

SK31 100 x 5 mm (innovative fixing)
SK50 50 x 5 mm
SK75 75 x 5 mm
SK100 75 x 5 mm



Wall protection Corner Guard CG22
22 x 22 mm

Powder coat
Anodized
Wooden finishes

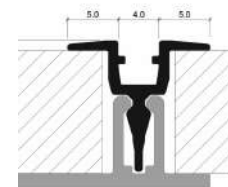

WP02

Simple snap-fit paneling system
Base channel on existing frame or surface
Snapfit top channel
Easily changeable panels



Can be used to fix any 10-11 mm board material
Gypsum board
Prelam particle board
Acoustic board
Lacquered glass pasted on base board
Soft board with fabric

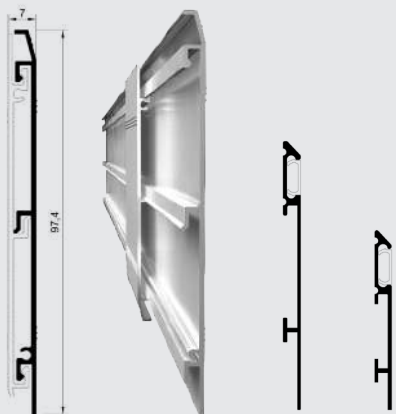

Carpet floor transition profile CP32
32 x 6 mm
can cover floor difference height of 10 to 12 mm

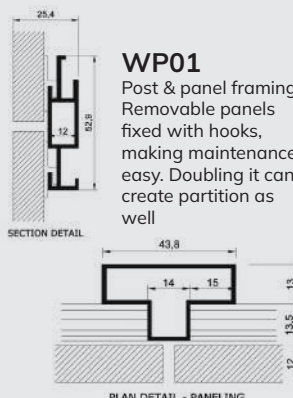

WP01

Post & panel framing
Removable panels fixed with hooks, making maintenance easy. Doubling it can create partition as well

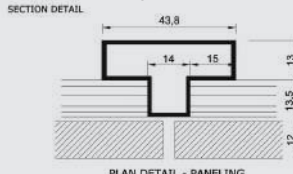



Give us a review

WE HELP

architects, designers, contractors & end-users to create dream interiors through our innovative, sustainable & highly customizable modular solutions. We can provide custom modular solutions as well

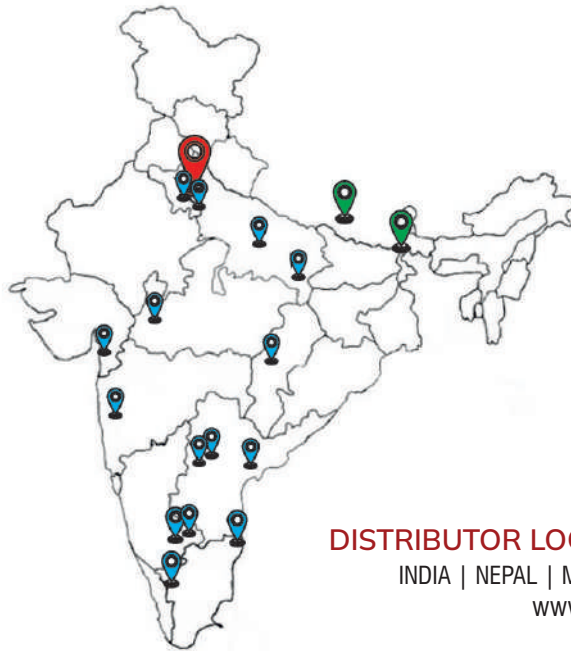

DISTRIBUTOR LOCATIONS
INDIA | NEPAL | MIDDLE-EAST
www.iqubx.com



View authorised distributors list online



IQUBX
Landing Page

IQUBX PVT LTD

Plot No 22, Khasra no 27/10 Industrial Area,
Nangli Sakrawati Near Campa Cola Factory
Najafgarh, New Delhi 110043

Iqubx Innovation Experience Center
G6, Ground Floor, Khasra No 405, Mehrauli-Gurgaon Rd,
Ghitorni, New Delhi 110030

www.iqubx.com

<https://www.facebook.com/iqubx/>

<https://www.linkedin.com/company/iqubx/>

<https://www.instagram.com/iqubx/>

PUBLISHED OCTOBER 2024

All copyrights, trademarks, Intellectual property rights, patents reserved in name of IQUBX pvt ltd and its directors. Any copying of logo, images, designs, product designs without explicit written permission of the directors of IQURX pvt ltd shall be a punishable offense. All the product designs are IPR protected.